

**INTERNATIONAL JOURNAL OF ENGINEERING SCIENCES & RESEARCH
TECHNOLOGY****DESIGN AND DEVELOPMENT OF FERTILIZER SPREADER MACHINE****Shailesh Chaudhari*, Mansuri Naeem, Prajapati Jigar, Prajapati Preyash**

* Student of Department of Mechanical Engineering, smt s.r patel engineering college dabhi, Unjha
Asst. Professor:- R.V Chaudhari, Department of Mechanical Engineering, Smt S.R patel engineering college dabhi, Unjha

DOI: 10.5281/zenodo.495879

ABSTRACT

India is agricultural based country. Our economy is also depends on agricultural related product. In the recent days it has been found that farmers are unable to gain more crop production by use of conventional agricultural methods. This project is based on manually fertilization process. A method is generated to spread the fertilizer over a fallow land by dropping the fertilizer over the impeller disc. The project design divided in to three level, top level, middle level, bottom level. Top level consists a solar module. Middle level consist a hopper, impeller disc, motor. The bottom level consists tires. The whole design is supported by frame and column. This project has solved the problem of traditional way of fertilization.

KEYWORDS: Fertilizer spreader, Flow control mechanism, centrifugal force, labor cost and fertilization time.

INTRODUCTION

India is agriculture based country. Near about 70% people of our country are farmers. Our economy also depends on agricultural products. Nowadays tremendous changes have occurred in conventional methods of agriculture like seed plantation, irrigation system, pesticides and spray used. For developing our Economic condition, it is necessary to increase our agricultural productivity and quality also. Farming process includes many stages, out of which fertilization is one of the important stages and which is not exploded up to the mark up till now. Now-a-days, we are used to do spreading of fertilizer in traditional way which is time consuming, costlier as well as not provide comfort to the labor. Also, some tractor operated machines for spreading of fertilizer are available. So, what we need is an alternative to the traditional as well as tractor operated fertilizer spreading machine which will fulfill all the requirements.

So, we are going to design a manually operated machine for fertilizer spreading by taking into consideration the user group and their needs which helps to them to work easy and functional.

PROBLEM DEFINITION

In the recent days it has been found that farmers are unable to gain more crop production by use of conventional agricultural methods. So there is big need for the development of engineering system for compensating these drawbacks. It is well known that by using farm equipment's, farmer's yields more crop productions which ultimately have impact on national economy. Itself it gives prior need of agro equipment's in the field of agriculture. As we can see today, the major problem faced by the farmers is shortage of labor's and also the time required for Fertilization is more. So in order to have solution to it, it was proposed to manufacture a Fertilizer Spreader machine. So, the farmers can work more easy and functional.

The Fertilizer Spreader machine should satisfy the following objectives:

- Fertilization process should be less time consuming.
- Portable
- Driven by manually
- Light weight
- Less cost
- User friendly

- Eco-friendly
- Maximum land cover

CONSTRUCTION AND WORKING

This project is based on manually fertilization process. A method is generated to spread the fertilizer over a fallow land by dropping the fertilizer over the impeller disc. The project design divided in to three level, top level, middle level, bottom level. Top level consists a solar module. Middle level consist a hopper, impeller disc, motor. The bottom level consists tires. The whole design is supported by frame and column

6.1 Hopper:-

- Hopper is used to keep fertilizer.
- Hoper is used for convey the fertilizer to the rotating disc.
- In this machine material used for hopper is PVC.
- Cross section of the hopper is circular.
- At the lower end of the hopper short PVC pipe is attached.
- Flow control mechanism is provide in hopper.

Specification:

Dimension of hopper

- Diameter = 12 inch =30cm
- Height =8 inch =20.32cm

Dimension of short cylindrical pipe

- Diameter =2.5cm
- Height =4cm

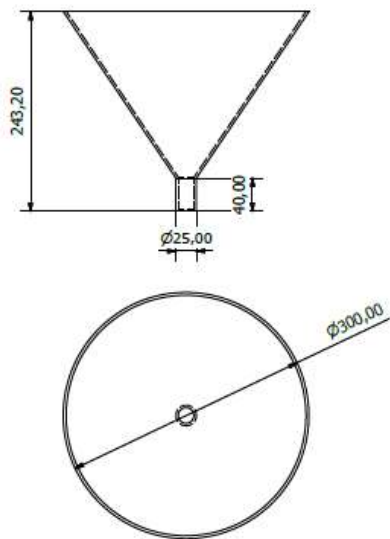

Hopper



6.2 Rotating disc:-

- Rotating disc is look like impeller.
- Rotating disc is mounted on motor shaft.
- Hopper opens on rotating disc eccentrically and due to centrifugal force fertilizer spread in farm.
- Wood is used for making a rotating disc.

Specification

- Diameter =8 inch =20.32cm
- Thickness =1.5cm

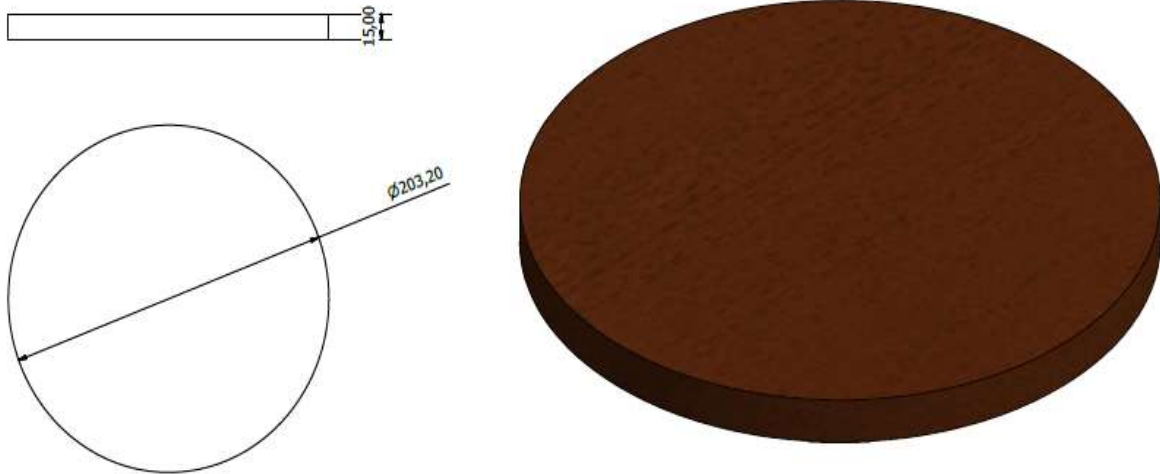

VERTICAL COLUMN

- In this project vertical column is used.
- In this project two vertical columns is used for support the solar plate, hopper, rotating disc, motor.
- Mild steel is use for making a vertical column.
- Vertical column is hollow and cross section of pipe is square.

Specification

- Height =40 inch =101.6cm
- Cross section = 4cm*4cm
- Thickness = 2.5cm

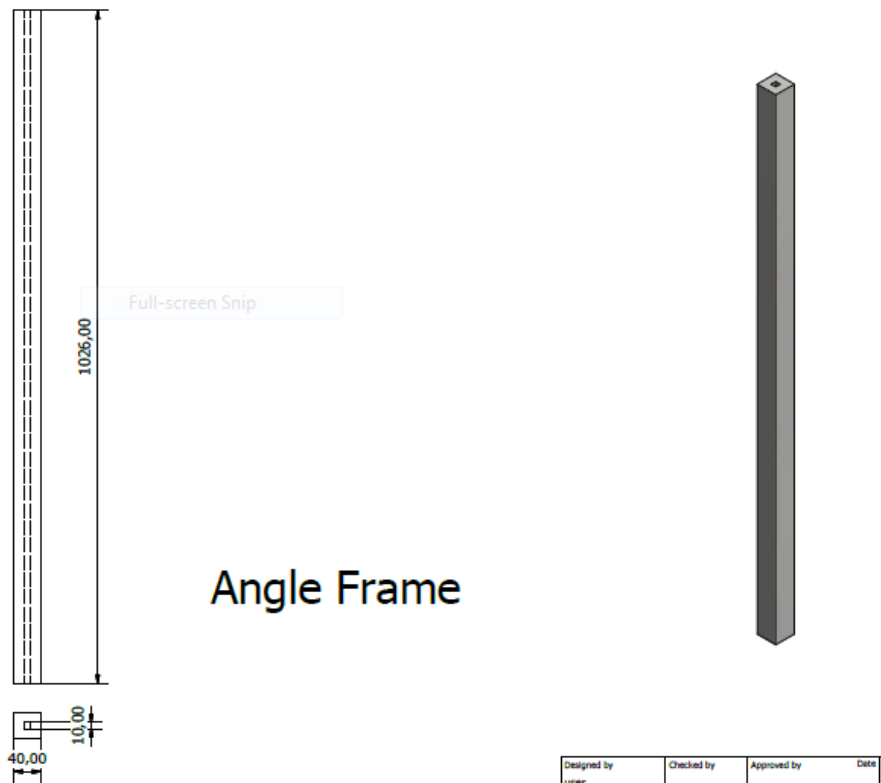

[FIGURE:- 6.3 vertical column]

Frame:-

- In this project the frame works as a supporting structure.
- In this project the frame can carry whole the machine.
- The Aluminum material used for making a frame.
- At bottom of the frame wheel are attached.

Specification

- Width of each plate = 3.8cm
- Thickness of each plate = 1.5cm

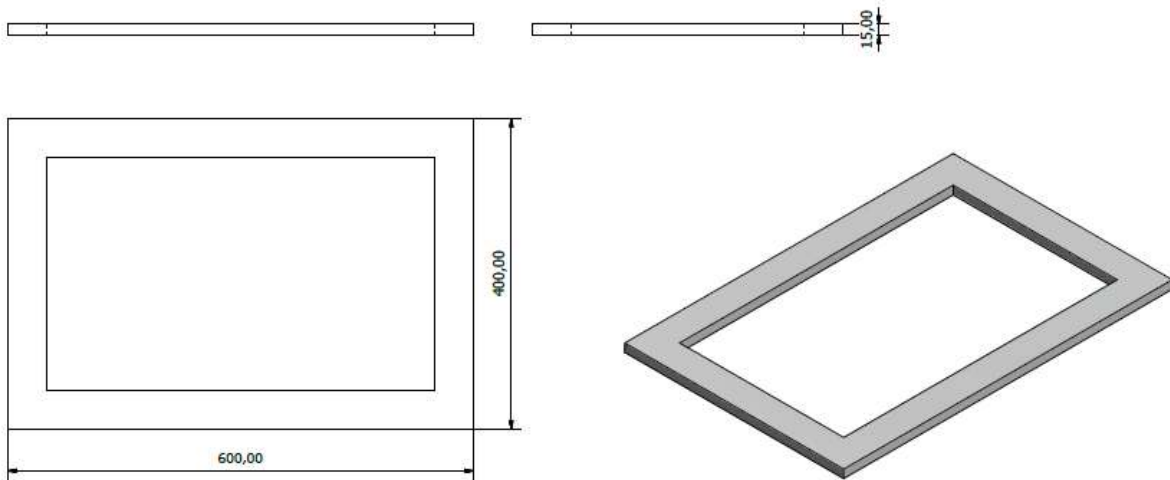

[FIGURE:- 6.6 Bottom frame]

Wheels:-

- The wheels are designed to carry the load of the runner it self and mass placed at top.
- According to load wheels are selected from standard size.
- Four wheels are attached to the frame in order to move the machine in specific direction.
- The movement of these wheels are controlled by DC motor rotation.



[FIGURE: 6.7 Wheels]

6.8 Motor:-

- Motor is one kind of prime mover of machine system which is used to supply power.
- Dc motor is an electric motor converts electrical energy into mechanical motion.
- In this machine motor is used for to rotate a rotating disc and drive the tires.

Calculation

8.1 Calculation for Location of impeller disc on column:-

- The following equation gives the estimate of how far the fertilization travel in the air according to location of impeller disc on column.
- In this project the following equation helps to determine location of disc.

$$H = \left\{ A * \frac{\sin[\theta - (\sin^{-1}(r * \sin \theta / A))]}{\sin \theta} \right\}$$

Where:

H = horizontal distance that the fertilizer travel in to the air.

A = vertical height column at disc is located.

r = radius of the disc = 10.16cm

θ = angle in degree.

Results

- In this project the target of the spreading the fertilizer is 60cm to 90cm, according to this vertical height A is varies between 50.08cm to 70.08cm. The angle is lies between 30degree to 60degree.

8.2 Calculation of buckling load in column:-

- In this project column is subjected to compressive load.
- Failure of column is occurred due to either crushing or buckling.
- It has also been observe, that all short columns fail due to their crushing.
- If a long column is subjected to compressive load, it is subjected to compressive stress. If the load is gradually increased, the column will reach a stage, when it will start buckling.
- The load at which column start to buckling is called as buckling load or critical load or crippling load.
- In this project the column of MS material is choose according to standard dimension and dimension is mentioned in section 6.3.
- In this project buckling load on column is calculate with the help of Euler's column theory.

Euler's column theory

$$W = C * \pi^2 * E * A * \frac{K^2}{l^2}$$

Where,

W= buckling load.

C= constant, representing end condition of column.

E= modulus of elasticity.

A= area of cross section.

K= least radius of gyration of cross section

L= effective length of column.

Input parameters

C= 4, because both end of column is fixed.

E= 200*10⁹ N/m².

A= 0.0015 m².

K=0.000119 m²

L= 0.508 m.

Result

- After putting all the input parameters in Euler's formula buckling load can be obtained and its value is W=64.99 N.

**Calculation of weight of hopper:-**

- In this project hopper is made out from PVC material.
- Cross section of hopper is circular, at the bottom end of hopper there is one short cylindrical pipe is attached, pipe material is also PVC.
- In this calculation bottom end of hopper is neglect.
- In this project for calculating the weight of hopper with pipe following equation is used:-

$$w = \left[\left(\frac{1}{3} * \pi * r^2 * h \right) + \left(\frac{\pi}{4} * d^2 * H \right) \right] * \rho * g$$

Where,

W= total weight of hopper and pipe.

r = radius of hopper at upper end.

h = height of hopper.

d = diameter of pipe.

H = height of pipe.

ρ = density of PVC

g = 9.81 m/s².

Input parameters

r = 15cm

h = 20.32cm

d = 2.5cm

H = 4 cm

ρ = 1.3 g/cm³

Result

- After putting all the input parameters in above equation total weight of hopper and pipe is obtained and its value w= 61.30 N.

8.4 Calculation of weight of rotating disc:-

- In this project rotating disc is made out from wood.
- Rotating disc is circular in shape.
- In this project for calculating weight of rotating disc the following formula is used:-

$$w = \frac{\pi}{4} * d^2 * t * \rho * g$$

Where,

d = diameter of rotating disc.

t = thickness of rotating disc.

ρ = density of wood.

g = 9.81 m/s²

Input parameters

d = 20.32cm

t = 1.5cm

ρ = 0.43 g/cm³

Result

- After putting all input parameters in above equation weight of rotating disc is obtained and its value is w= 2.052 N.

8.5 Checking for column failure:-

- In section 8.2 we find critical buckling load for one column and its value is 64.99N. In this project two columns is used.

$$\text{Total critical buckling load} = 2 * 64.99 = 129.98\text{N}$$

- In this machine the weight of hopper with fertilizer, rotating disc, solar panel, motor, are transferred in column.

Assume:-

- Weight of hopper with fertilizer=61.30+39.24=100.54N
 - Weight of solar panel =1.5*9.81 = 14.71N
 - Weight of motor= 0.3*9.81 = 2.943N
 - Weight of rotating disc = 2.052N
- Total load transfer on column = 120.245N

RESULT

- Here total load acting on column is less than the critical buckling load. So column is safe. So dimension is correct.

Checking for frame failure:-

- The Aluminum material used for making a frame.
- Frame work as a beam & it is subjected to point load.
- Total load acting on frame can be calculated by following equation:-

$$\begin{aligned} \text{Total load acting on one frame} &= (\text{weight of column}) + (1/2 * \text{weight of hopper with fertilizer}) \\ &+ (1/2 * \text{weight of solar panel}) + (1/2 * \text{weight of motor}) \\ &+ (1/2 * \text{weight of rotating disc}) \end{aligned}$$

- Weight of column = $\rho * v * g = 7.85 \text{ gm/cm}^3 * 1524 \text{ cm}^3 * 981 \text{ cm/s}^2 = 116.91 \text{ N}$

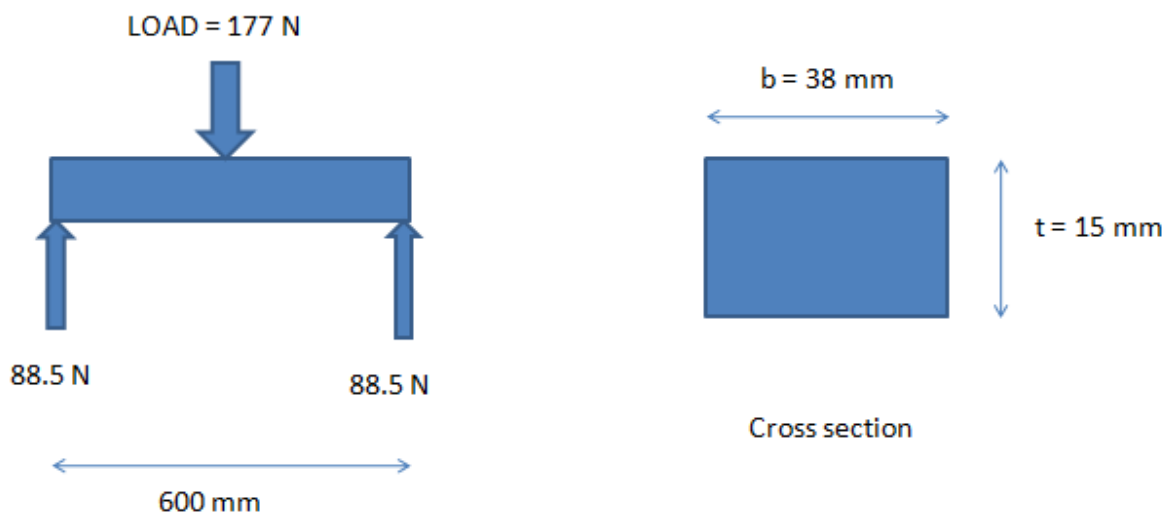

- Maximum bending moment acting on frame = $(\text{Total load} * L) / 4$
= $(177 * 600) / 4$
= **26550 N**
- Moment of inertia about X-X axis = $(1/12) * b * t^3 = 10687.5 \text{ mm}^4$
- Bending stress = $(M / I) * Y = (26550 / 10687.5) * 7.5 = 18.631 \text{ N/mm}^2$
- Ultimate Tensile Strength = 310 MPa & Yield Strength = 275 MPa of aluminum
- Factor of safety = 1.5

Results:- Maximum bending stress is less than allowable stress of aluminum, so design is safe.

CONCLUSION

- Our goal is to be build a system which is efficient to perform a various application with manually fertilizer spreader machine.
- With the scope of improvement, the project is done to fulfill the demand of agricultural application.
- The main objective of this project is to fulfill the need of farmers suffering from the problem of increasing cost of fertilization, labor cost, availability as it is operated by single person.
- With this machine, percentage reduction in time required for fertilization was observed to be 50% and reduction in labor cost as compared to conventional method was 80%.
- It has solved the problem of traditional way of fertilization. Since the capital cost is essential factor while selecting equipment for farming. This machine has very less capital cost as compare to other conventional equipment.
- By undergoing all this discussion and undergoing all the factors associated with fertilization, this machine will be great boon for the Indian agricultural

REFERENCES

- [1] Loren E. Tyler, Benson, Minn, assignor to Tyler Manufacturing Company, in Apr 1963, “fertilizer spreader” Patent No :- US3539112
- [2] Carlo Bezzecchi, 3, Via dei Tigli, Campagnola, in July 1973, “swinging tube type fertilizer spreader”
- [3] Donald R. Gallogly, William E. Wheeler, in July 1971 “seed and fertilizer spreader” Patent No:- US3730395
- [4] Clifford h. Snyder, in March 1967 “Fertilizer spreader” Patent No:- US32236527
- [5] W.H. STILITER, in July 1965 “Fertilizer spreader machine” Patent No:- US2522693
- [6] DIENER ROBERT, in March 1953 “Belt fertilizer spreader” Patent No:- US3746256
- [7] Cichy Steve J. In March 1987 “cartridge spreader system” Patent No:- US8382014
- [8] J. S. CLARPER, in 1927 “MACHINE FOR SPREADING FERTILIZER”
- [9] J. N. VANDER POL, in July 1966 “Farm machine to load, transport and spread liquid, semi-solid fertilizer” Patent No:- US3294407
- [10] A. A. HURT, in Aug. 1960 “fertilizer mixing and spreading machine” Patent No:- US2947544
- [11] J. D. KIRSCHMANN in Sept. 1957 “fertilizer spreader” Patent No:- US2804998
- [12] J. R. BARBER ET AL in July 1957 “SPREADER FOR FERTILIZER AND THE LIKE” Patent No:- US2797847